

# Voltage Flicker Compensation using STATCOM to Improve Power Quality

D.Lavanya<sup>1</sup>

B.Srinu<sup>2</sup>

<sup>1</sup>M.tech Scholar (EPS), Anurag Engineering College, Kodad, Telangana, India

<sup>2</sup>Assistant Professor (EEE), Anurag Engineering College, Kodad, Telangana, India

**Abstract**— Voltage flicker is considered as one of the most severe power quality problems (especially in loads like electrical arc furnaces) and much attention has been paid to it lately. Due to the latest achievements in the semiconductors industry and consequently the emergence of the compensators based on voltage source converters, FACTS devices have been gradually noticed to be used for voltage flicker compensation. This paper covers the contrasting approaches; dealing with the voltage flicker mitigation in three stages and assessing the related results in details. Initially, the voltage flicker mitigation, using FCTCR (Fixed Capacitor Thyristor Controlled Reactor), was simulated. Secondly, the compensation for the Static Synchronous Compensator (STATCOM) has been performed. In this case, injection of harmonics into the system caused some problems which were later overcome by using 12-pulse assignment of SATCOM and RLC filters. The obtained results show that STATCOM is very efficient and effective for the flicker compensation. All the simulations have been performed on the MATLAB Software.

**Index Terms** Power Quality, Voltage Flicker, Static Synchronous Compensator (STATCOM)

## I. INTRODUCTION

The relationship between power quality and distribution system has been a subject of interest for several years. The concept of power quality describes the quality of the supplier voltage in relation to the transient breaks, falling voltage, harmonics and voltage flicker. Voltage Flicker is the disturbance of lightning induced by voltage fluctuations. Very small variations are enough to induce lightning disturbance for human eye for a standard 230V, 60W coiled-coil filament lamp. The disturbance becomes perceptible for voltage variation frequency of 10 Hz and relative magnitude of 0.26%. Huge non-linear industrial loads such as the electrical arc furnaces, pumps, welding machines, rolling mills and others are known as flicker generators. In this respect, the quality of supplied voltage is significantly reduced in an electrical power system and the oscillation of supplied voltage appears to be a major problem.

Electric arc furnace, the main generator of voltage flicker, behaves in the form of a constant reactance and a variable resistance. The transformer-reactance system is modelled as a lumped reactance, a furnace reactance (included connection cables and busses) and a variable resistance which models the arc. Connecting this type of load to the network produces

Voltage variation at the common point of supply to other consumers. The relative voltage drop is expressed by equation (1):

$$\frac{\Delta U}{U_n} = \frac{R\Delta P + X\Delta Q}{U_n^2} \quad (1)$$

Where  $\Delta P$  and  $\Delta Q$  are the variation in active and reactive power;  $U_n$  is the nominal voltage and  $R$  and  $X$  are short circuit resistance and reactance. Since  $R$  is usually very small in comparison to  $X$ ,  $\Delta U$  is proportional to  $Q$  (reactive power). Therefore, voltage flicker mitigation depends on reactive power control.

Two types of structures can be used for the compensation of the reactive power fluctuations that cause the voltage drop:

A: shunt structure: in this type of compensation, the reactive power consumed by the compensator is kept constant at a sufficient value.

B: series structure: in this type, all the efforts are done to decrease the voltage drop mentioned above, and finally the reactive power is kept constant despite the load fluctuations by controlling the line reactance.

bumpy ride in an elevator, in other instances the effects can be harmful to electrical equipment. Typically, the deleterious effects of power frequency disturbances are predominantly felt in the long run and such disturbances do not result in immediate failure of electrical devices. The effects of power frequency disturbances vary from one piece of equipment to another and with the age of the equipment. Equipment that is old and has been subjected to harmful disturbances over a prolonged period is more susceptible to failure than new equipment. Fortunately, because power frequency disturbances are slower and longer lasting events, they are easily measured using instrumentation that is simple in construction. Most common power quality problems are:

- (a) Voltage sag (dip)
- (b) Voltage swell
- (c) Harmonics
- (d) Interruptions
- (e) Voltage spike
- (f) Noise
- (g) Voltage unbalance
- (h) Distortions
- (i) Transients
- (j) Voltage flicker

A two-bus system is exploited to fulfil the investigation of the presented procedure. All the simulations are done according to the usage of MATLAB software. The related compensation was performed first by FCTCR. Afterwards, a 6-pulse voltage-source converter STATCOM was used to compensate for the voltage flicker. With respect to the harmonic problem in this stage, a 12-pulse voltage-source converter STATCOM was designed to isolate load harmonics and mitigate the propagation of voltage flicker to the system in the next stage. The obtained results clearly confirmed the efficiency of the 12-pulse STATCOM to complete the voltage flicker mitigation.

## II. CONTROLLING SYSTEM

The concept of instantaneous reactive power is used for the controlling system. Following this, the 3-phase voltage upon the use of the park presented by Akagi has been transformed to the synchronous reference frame (Park or dq0 transformation). This transformation leads to the appearances of three instantaneous space vectors:  $V_d$  on the d-axis (real or direct axis),  $V_q$  the q-axis (imaginary or quadrature axis) and  $V_0$ , from the 3-phase voltage of  $V_a$ ,  $V_b$  and  $V_c$ . The related equations of this transformation, expressed in the MATLAB software, are as follows:

A new technique based on a novel control algorithm, which extracts the voltage disturbance to suppress the voltage flicker, is presented in this thesis. The concept of instantaneous reactive power is used for the controlling system. Following this 3Ø flicker voltage has been transformed to synchronous reference frame by the use of abc to dqo transformation (Park's transformation). To implement the synchronous reference frame some kind of synchronizing system (phased looked loop) should be used.

3Ø AC system load voltage is the input to the phase locked loop (PLL), this PLL can be used to synchronize on a set of variable frequency, and 3Ø sinusoidal signals. 3Ø PLL block provides three outputs.

From the output of PLL  $\sin\omega t$  and  $\cos\omega t$  value are given to abc to dqo transformation, this transformation leads to the appearances of three instantaneous space vectors:  $v_d$  on the d-axis (real or direct axis),  $v_q$  on the q-axis (imaginary or quadrature axis) and  $v_0$ , from 3 - Ø phase flicker voltage of  $v_a$ ,  $v_b$  and  $v_c$ . The related equations of this transformation, expressed in the MATLAB Simulink software, are as follows:

$$V_d = \frac{2}{3} (V_a \sin(\omega t) + V_b \sin(\omega t - \frac{2\pi}{3}) + V_c \sin(\omega t + \frac{2\pi}{3}))$$

$$V_q = \frac{2}{3} (V_a \cos(\omega t) + V_b \cos(\omega t - \frac{2\pi}{3}) + V_c \cos(\omega t + \frac{2\pi}{3})) \quad (4.1)$$

$$V_0 = \frac{1}{3} (V_a + V_b + V_c)$$

Network. If the compensation current of the above equation is injected to the network, the whole voltage flicker existing in the network will be eliminated. Regarding the equation, related to the dq-transformation of the 3-phase-voltages to the instantaneous vectors, it is obvious that under the conditions of accessing an average voltage flicker,  $V_d$  and  $V_0$ , the obtained values are close to zero and  $V_q$  is a proper value adapting to the voltage oscillation of the network. This state of the 3-phase voltage flicker is presented in the following figures (simulated in the MATLAB Simulink package):

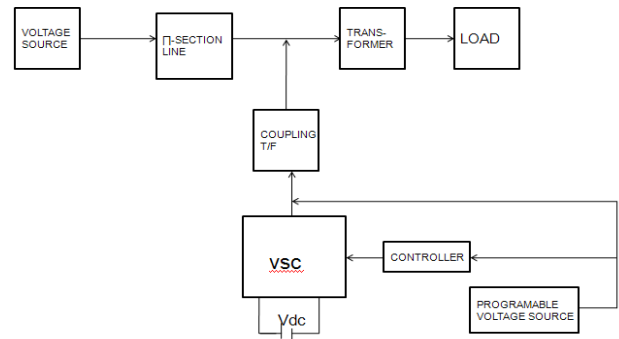

Fig.1 Block diagram of the investigated power system

Park's Transformation of 3-phase flicker voltage to the instantaneous vector's is given to demux block, it extract the component of an input signal and output's the components as separate signals  $V_d$ ,  $V_q$  and  $V_0$ . The active and reactive components of the system are represented by the direct and quadrature component, respectively, the decrease of the voltage flicker of the network and the compensating control to decrease the voltage flicker can be limited only based on the amount of the imaginary component of the instantaneous voltage ( $V_q$ ), so to decrease the voltage flicker controlling system uses only  $V_q$  to control the STATCOM, the obtained  $V_q$  is entered as an input to the sum block and other input to the sum block is constant value zero, it indicates the  $V_q$  per unit reference value.

In sum block plus and minus signs indicate the subtraction or comparison operation to be performed on the inputs, resultant is the sum block output as the error signal is given to PI controller. PI controller output signal is firing

angle component in radians, it is multiple by the gain of  $\frac{180}{\pi}$

to get in degrees, and this firing signal is given to the input of pulse generator to control the pulses of the generator. The inputs AB, BC, CA are the phase - phase voltages these are given from the 3Ø flicker voltage. Step value is block reference value. Pulse generator output contains the pulse signal (pulse width 10 degree is specified) are to be sent to the voltage source converter to trigger the power switching devices (GTO's) of the STATCOM, to produce required magnitude of voltage and injection or absorption of reactive power.

**Simulation of 6-pulse voltage source converter STATCOM connected to the Power System**

The load voltage and the flicker source voltage are given to phase locked loop (PLL) and ABC to dq transformation blocks respectively. From the control circuit trigger pulse are given to the corresponding GTO's, by adjusting the conducting angle of the GTO's the generated voltage and then the injected or absorbed reactive power of the STATCOM are controlled. shows SIMULINK diagram of 6 pulse voltage source converters STATCOM connected to the power system.

Shows the compensated output load voltage and harmonic spectrum respectively by 6 pulse voltage source converter STATCOM. It can be observed that the compensated output load voltage is 1.15pu (maximum value), the voltage flicker existing in the output load voltage is 0.15pu (15%), the considerable existing characteristic harmonics in the output load voltage wave form in addition to the fundamental component are 5<sup>th</sup>, 7<sup>th</sup>, 11<sup>th</sup>, 13<sup>th</sup> and higher. It can be observed from the harmonic spectrum that THD is 8.95%. 5<sup>th</sup>, 7<sup>th</sup>, 11<sup>th</sup> and 13<sup>th</sup> harmonic should be eliminated from the output load voltage.

**Simulation of 12-pulse voltage source converter STATCOM connected to the power system:**

In this compensation, pulse generator outputs 1 and 2 are two vectors of six pulses, are given to the two 6-pulse converters connected respectively to the Y winding and Δ connected windings of 3Ø transformer (three windings). The pulse train to one converter is shifted by 30 degrees with respect to the other. Fig 5.6 shows SIMULINK diagram of 12 pulse voltage source converters STATCOM connected to the power system. The output load voltage mitigated by 12-pulse voltage-source converter STATCOM and its harmonic spectrum are shown in figures 5.7 and 5.8 respectively. In this respect, the voltage flicker is completely removed from the output load voltage. It can be observed from the harmonic spectrum that THD is 4.47%.

**Simulation of 12-pulse voltage source converter STATCOM with 3Ø harmonic filter connected to the power system:**

To eliminate lowest order harmonics such as 11<sup>th</sup> and 13<sup>th</sup> harmonic, double tuned band pass filter is connected across the 12 pulse voltage source converter output. SIMULINK diagram of 12 pulse voltage source converters STATCOM with 3Ø harmonic filter connected to the power system. The output load voltage mitigated by 12-pulse voltage-source converter STATCOM with 3Ø harmonic filter and its harmonic spectrum respectively. In this respect, the voltage flicker is completely removed from the output load voltage and a sinusoidal waveform is obtained. It can be observed from the harmonic spectrum that THD is 2.30%.

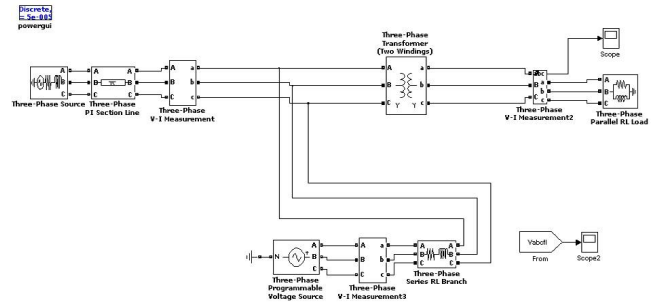

Fig.2 SIMULINK diagram of a two bus power system without STATCOM

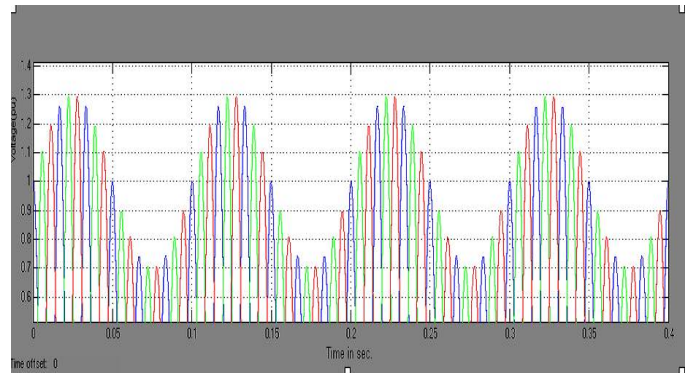
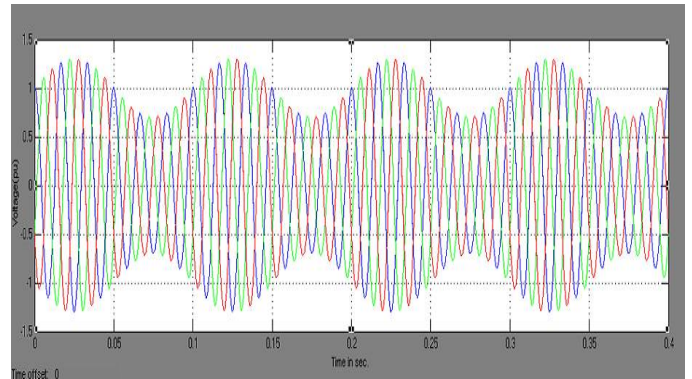

Fig.3. Output load voltage without STATCOM.

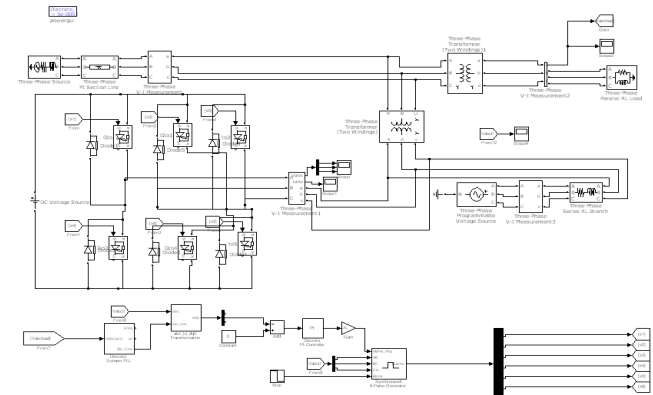

Fig.4 SIMULINK diagram of 6 pulse voltage source converter STATCOM connected to the power system.

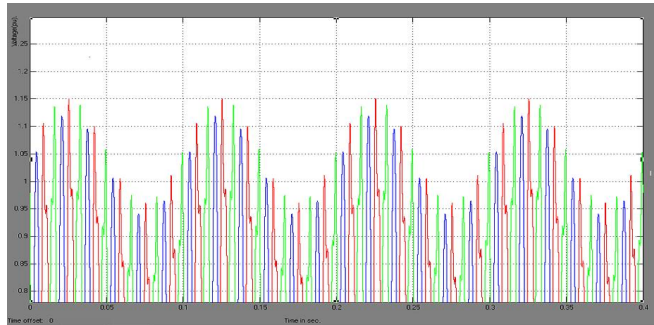
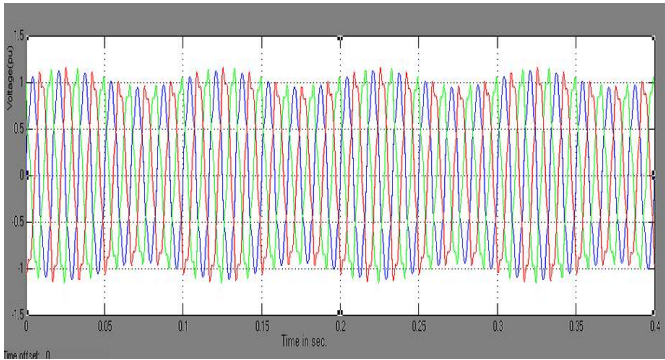

Fig.5 Compensated output load voltage by 6-pulse voltage source converter STATCOM

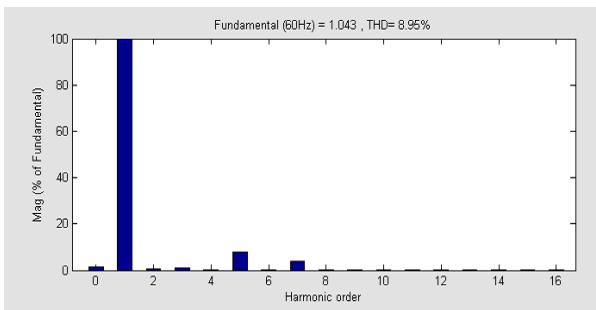

Fig. 6 Harmonic spectrum of the compensated output load voltage by 6-pulse voltage-source converter STATCOM.

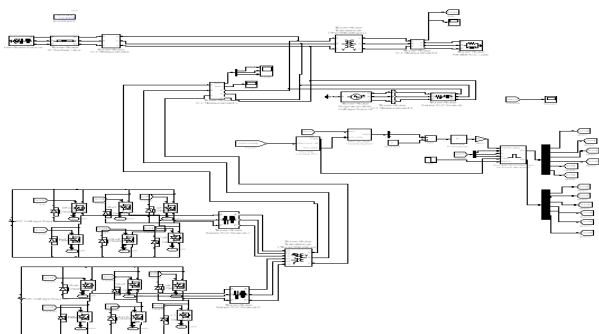

Fig.7 SIMULINK diagram of 12 pulse voltage source converter STATCOM connected to the power system.

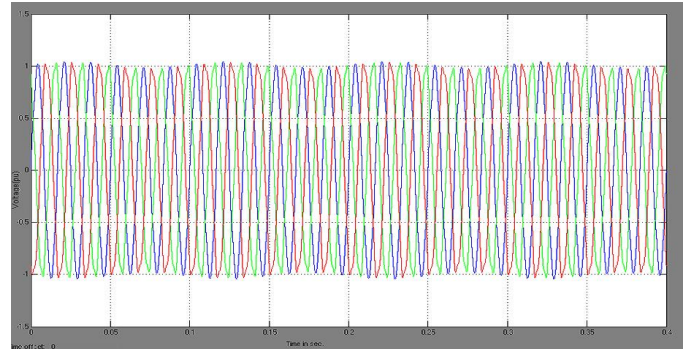

Fig.8 Output load voltage mitigated by 12-pulse voltage source converter STATCOM

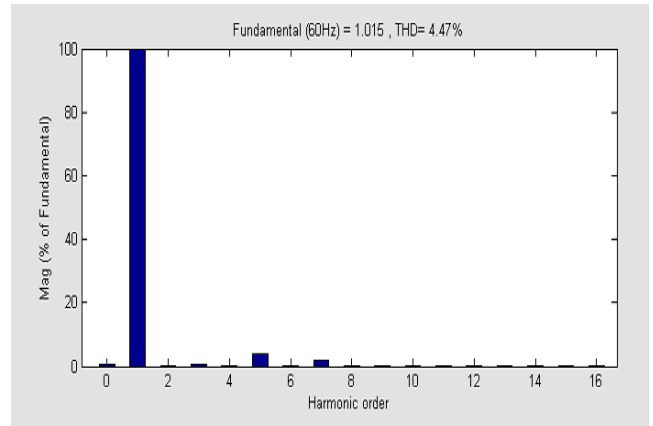

Fig.9 Harmonic spectrum of the output load voltage mitigated by 12-pulse voltage source converter STATCOM.

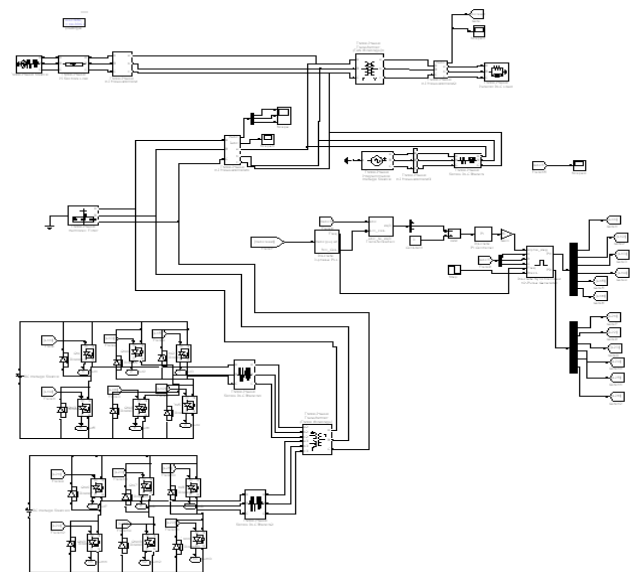

Fig.10 SIMULINK diagram of 12 pulse Voltage source converter STATCOM with 3Ø harmonic filter connected to the power system.

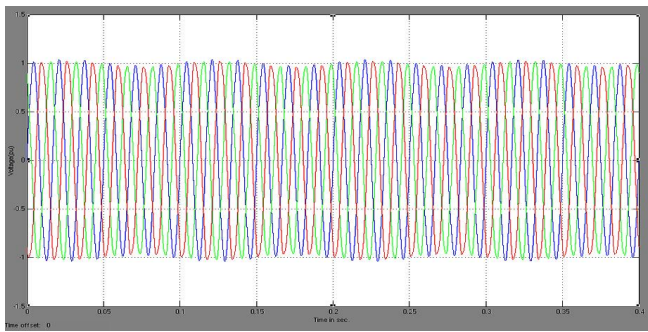

Fig.11 Output load voltage mitigated by 12-pulse voltage source converter STATCOM with 3 $\phi$  harmonic filter

### III. CONCLUSION

In this paper, the application of STATCOM technology based on voltage-source converters for voltage flicker mitigation has been investigated and simulation results emphasized its significant effect. A 6-pulse STATCOM is decreasing the voltage flicker by 50%. However, there is injection of the harmonic from 6-pulse STATCOM into the system which can be improved with the increase of the voltage source converters of STATCOM using a 12-pulse STATCOM equipped with a harmonic filter. The obtained results clearly demonstrate that 12-pulse STATCOM equipped with a harmonic filter can reduce the voltage flicker completely and the output is obtained with minimum THD Value.

### REFERENCES

- [1] J. Sun, D. Czarkowski, Z. Zabar, "Voltage Flicker Mitigation Using PWM-Based Distribution STATCOM", IEEE Power Engineering Society Summer Meeting, Vol.1, (21-25 July 2002), pp. 616-621.
  - [2] N. G. Hingorani, L. Gyugyi, "Understanding FACTS", IEEE Press.
  - [3] Rozmyslaw, Miensik, Ryszard.pawelk, "Application of STATCOM controllers for power quality improvement-Modelling and simulation." IEEE Trans. (2002), 0-7803-7671102
  - [4] L. Tang, S. Kolluri, M.F. McGranaghan, "Voltage Flicker Prediction for Two Simultaneously Operated AC Arc Furnaces" IEEE Trans. on Power Delivery; Vol.12, No.2, (1997), pp. 985-991.
  - [5] M. Zouiti, S. Saadate, X. Lombard, C. Poumarede, C. Levillain, "Electronic Based Equipment for Flicker Mitigation", Proceedings of International Conference on Harmonics And Quality of Power, Vol.2, (1998), pp. 1182-1187.
  - [6] T. Larsson, C. Poumarede, "STATCOM, an efficient means for flicker mitigation" IEEE Power Engineering Society Winter Meeting, Vol.2, (Jan-4Feb 1999), pp. 1208-1213.
  - [7] C. S. Chen, H. J. Chuang, C. T. Hsu, S. M. Tscng, "Stochastic Voltage Flicker Analysis and Its Mitigation for Steel Industrial Power Systems", IEEE Power Tech Proceedings, Vol.1, (10-13 Sept. 2001).
  - [8] Z. Zhang, N. R. Fahmi, W. T. Norris, "Flicker Analysis and Methods for Electric Arc Furnace Flicker (EAF) Mitigation (A Survey)", IEEE Power Tech Proceedings, Vol.1, (10-13 Sept. 2001).
  - [9] J. R. Clouston, J. H. Gurney, "Field Demonstration of a Distribution Static Compensator Used to Mitigate Voltage Flicker", IEEE Power
- International Journal of Emerging Trends in Electrical and Electronics (IJETEE – ISSN: 2320-9569)*

Engineering Society Winter Meeting, Vol.2, (31 Jan-4 Feb 1999), pp. 1138-1141.

[10] A. Elnady, W. El-khattam, M. A. Salama, "Mitigation of AC Arc Furnace Voltage Flicker Using the Unified Power Quality Conditioner", IEEE Power Engineering Society Winter Meeting, Vol.2, (27-31 Jan. 2002), pp. 735-739.

[11] S. Suzuki, Y. Hara, E. Masada, M. Miyatake, K. Shutoh, "Application of Unified Flow Controller for Power Quality Control at Demand Side", The Third International Power Electronics and Motion Control Conference Proceedings (PIEMC 2000), Vol.3 (15- 8Aug 2000), pp. 1031-1036.

[12] Y. Hara, E. Masada, M. Miyatake, K. Shutoh, "Application of Unified Flow Controller for Improvement of Power Quality" IEEE Power Engineering Society Winter Meeting, Vol.4, (23-27 Jan. 2000), pp. 2600-2606.



**First Author: D.Lavanya** completed her B.Tech from Anurag engineering college in 2013, and present pursuing her M.Tech (EPS) in Anurag Engineering College.



**Second Author: B.Srinu** completed his B.Tech in CJITS and M.Tech in power electronics From JNTUCEH, Hyderabad. Presently he is working as assistant professor, Department of EEE in Anurag Engineering College. His interested areas are research in power electronics applications in power systems, electrical machines, FACTS & HVDC applications.